

Oroflex[®] Flowstream

tipsa 

INSTALLATION MANUAL



CONTENTS

1. DESCRIPTION OF OROFLEX FLOWSTREAM FLEXIBLE RISER AND COUPLINGS.....	4
2. INSTALLATION TECHNIQUES FOR OROFLEX FLOWSTREAM FLEXIBLE RISING MAIN SYSTEM.....	8
- 2.1 Riser length and coupling attachment.....	8
- 2.2 Assembly procedure.....	8
3. POWER CABLE ATTACHMENT.....	12
- 3.1 Polyurethane rounding strap & stainless steel buckle.....	13
- 3.2 Saddle + cable tie.....	14
4. INSTALLATION TECHNIQUES.....	17
- 4.1 Vehicle Assisted Installation.....	17
- 4.2 Crane Installation.....	20
- 4.3 Manual Installation.....	23
5. RETRIEVAL OF OROFLEX FLOWSTREAM FLEXIBLE RISING MAIN SYSTEM.....	24
- 5.1 Drilled non-return valve.....	24
- 5.2 Draining break-off fuse.....	24
6. LIFTING AN OROFLEX FLOWSTREAM COLUMN FULL OF WATER.....	25
7. CONSIDERATIONS BEFORE INSTALLING THE RISER.....	26
8. CENTERING DEVICE.....	27
9. TOOLS REQUIRED FOR INSTALLATION AND RETRIEVAL OF OROFLEX FLOWSTREAM.....	29
10. COUPLING SPECIFICATIONS.....	30

FOREWARD

OROFLEX FLOWSTREAM is a high quality and resistant, flexible and self-supporting lay flat rising main ideal for installing submersible pumps. Installation time and manpower costs are greatly reduced using **OROFLEX FLOWSTREAM**.

Lightweight, flexible and compact, **OROFLEX FLOWSTREAM** is simple to use, transport and store. **OROFLEX FLOWSTREAM** is superior to conventional systems. The reliability and stability of its components assures it will not corrode.

OROFLEX FLOWSTREAM SYSTEM DESCRIPTION

WELL DRILLING IS ONE OF THE MOST ANTIQUE WATER EXTRACTION METHODS. NOWADAYS, IN A CONTEXT OF GLOBAL WATER SHORTAGE, THE EXPLOITATION OF HYDROLOGICAL RESOURCES ACQUIRES GREAT IMPORTANCE.

AT **TIPSA** WE HAVE DEVELOPED THE **OROFLEX FLOWSTREAM** SYSTEM FOR SUBMERSIBLE PUMP INSTALLATIONS; OFFERING SUBSTANTIAL TECHNICAL AND ECONOMICAL ADVANTAGES WHEN EASILY OBTAINING UNDERGROUND WATER.

THE FLEXIBLE **OROFLEX FLOWSTREAM** WELLRISER SYSTEM INCLUDES A WIDE RANGE OF FLEXIBLE PIPELINES AND ACCESSORIES SPECIALLY DESIGNED FOR WATER WELLS, FOR USE IN DIFFERENT AREAS OF APPLICATION SUCH AS:

- DEWATERING
- APPRAISAL OF WATER WELLS
- WATER MONITORING
- INDUSTRY WATER SUPPLY
- AGRICULTURE
- DRAINING
- DESALINATION PLANTS
- MARINE AND OFFSHORE INDUSTRY
- LEACHATE EXTRACTION ON LANDFILL SITES

ADVANTAGES OF THE OROFLEX FLOWSTREAM SYSTEM

- INSTALLATION COST SAVINGS
- SAVINGS IN ELECTRICITY CONSUMPTION
- EASY HANDLING
- EASY TO STORE AND TRANSPORT
- COMPLETE SYSTEM OF FLEXIBLE PIPES AND ACCESSORIES
- PREVENTS NOISE AND VIBRATIONS
- PREVENTS CORROSION AND INCRUSTATIONS
- MAXIMISES WATER FLOW IN NARROW WELLS
- RECOMMENDED FOR CURVED OR IRREGULAR WELLS
- SUITABLE FOR POTABLE WATER
- CHEMICAL RESISTANCE
- LONG OPERATIONAL LIFE OF INSTALLATIONS

1. DESCRIPTION OF OROFLEX FLOWSTREAM FLEXIBLE RISER AND COUPLINGS:

RISER CONSTRUCTION AND MATERIALS

- Lay flat hose extruded through the weave
- Textile: High tenacity polyester - Circular woven
- Inner and outer layer: Polyether Polyurethane (PU)
- Incorporates a strip of reinforced polyurethane on the side to support the electrical cables and accessories
- Colour: Blue

GENERAL CHARACTERISTICS:

Diameter	inch	1 ½	2	2 ½	3	4	5	6
	mm	38	51	63	76	102	127	152
Burst pressure	bar	75	57	57	57	57	57	57
Tensile strength - maximum	kg	3.800	4.000	6.600	7.000	12.000	15.000	20.000
Recommended loading - maximum (a)	kg	1.300	1.600	2.200	2.800	4.800	6.000	8.000
Weight without couplings	gr/m	400	570	800	980	1.400	2.000	2.610
Expansion - maximum	%	15	15	15	15	15	15	15
Elongation - maximum	%	0 to 2						
Working pressure	bar	26	26	26	26	26	25	25
External coupling diameter (Maximum)	mm	70	99	120	130	165	196	227
Service Temperature	°C	-40 a +50						
pH water below 30°C		4 a 9						
pH water between 30°C and 50°C		5 a 9						
Length		Long continuous length						
Maximum recommended flow	l/sec	4	8	11	20	33	50	75

(a) Including hose weight, cable, couplings, other accessories, pressure at the top of the well, and weight of the water.

HYDRAULIC PERFORMANCE:

Friction loss Oroflex Flowstream 2"

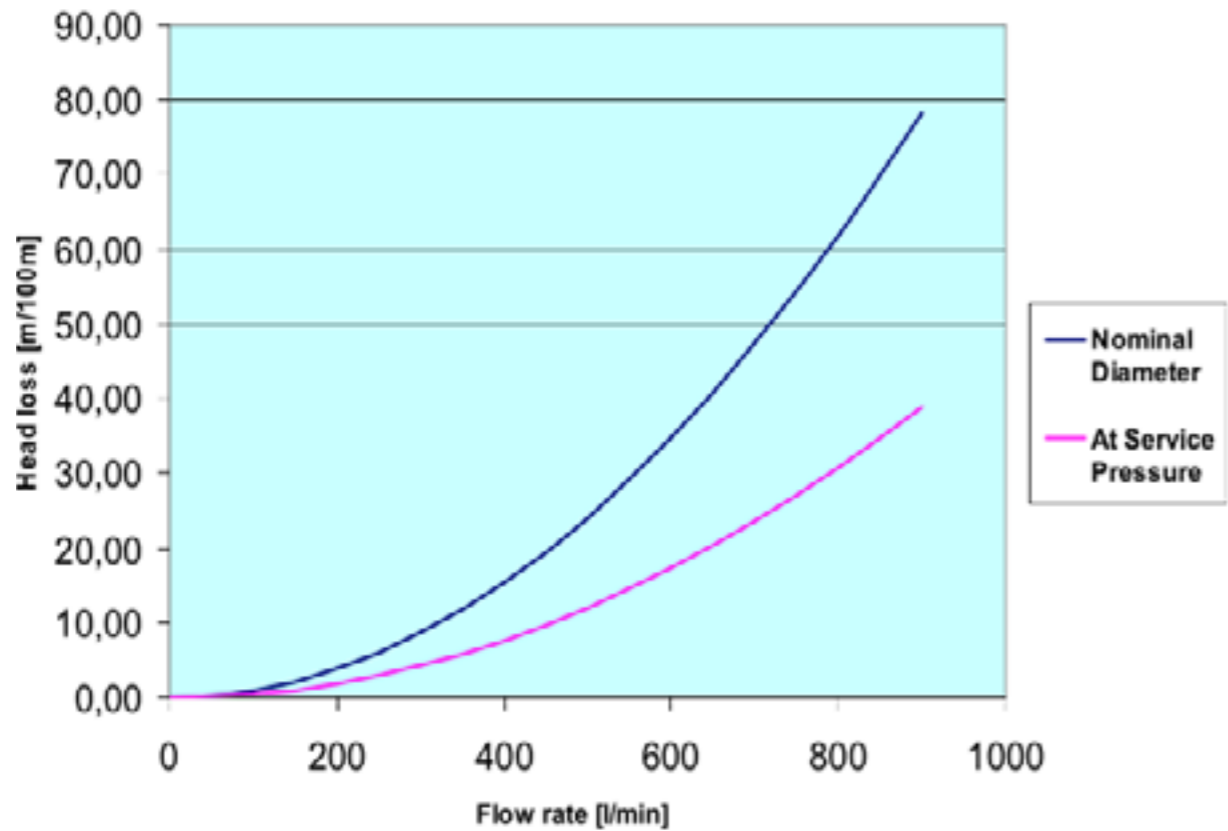

Friction loss Oroflex Flowstream 3"

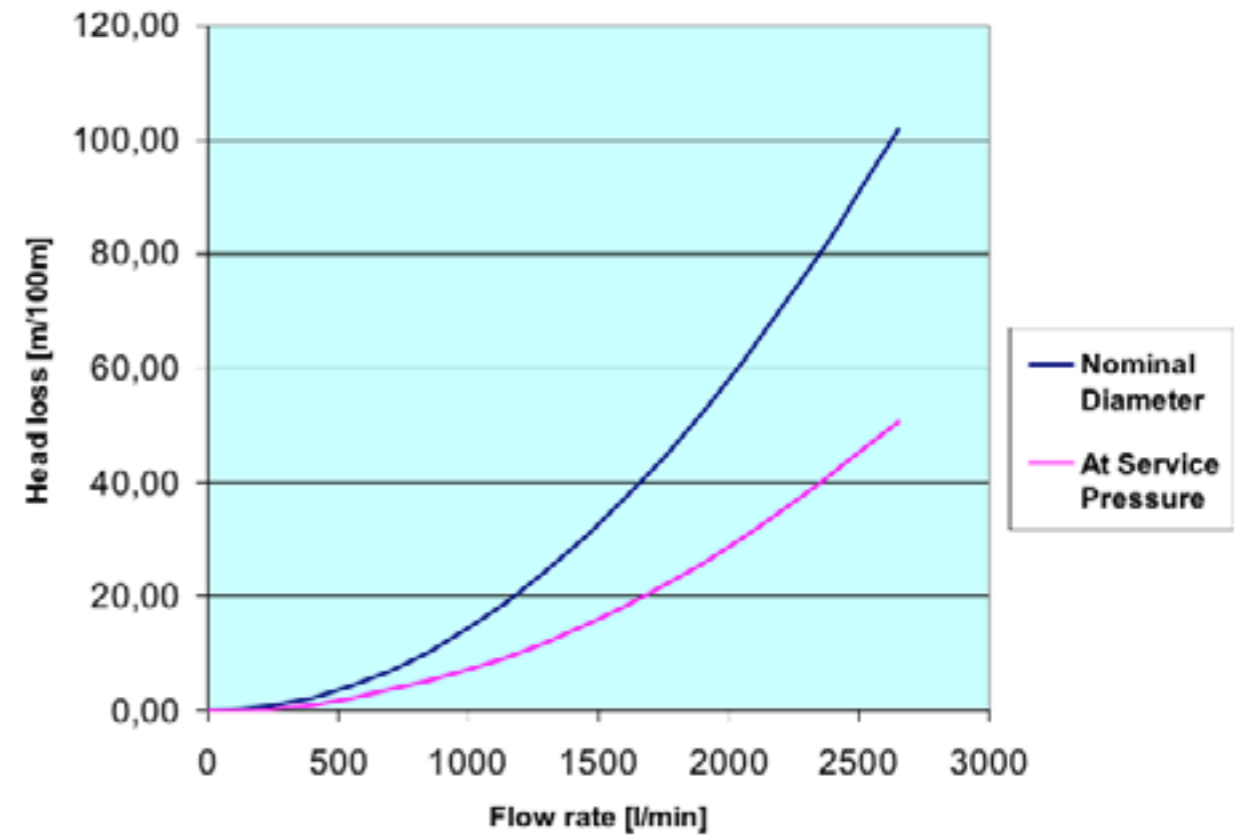

HYDRAULIC PERFORMANCE:

Friction loss Oroflex Flowstream 4"

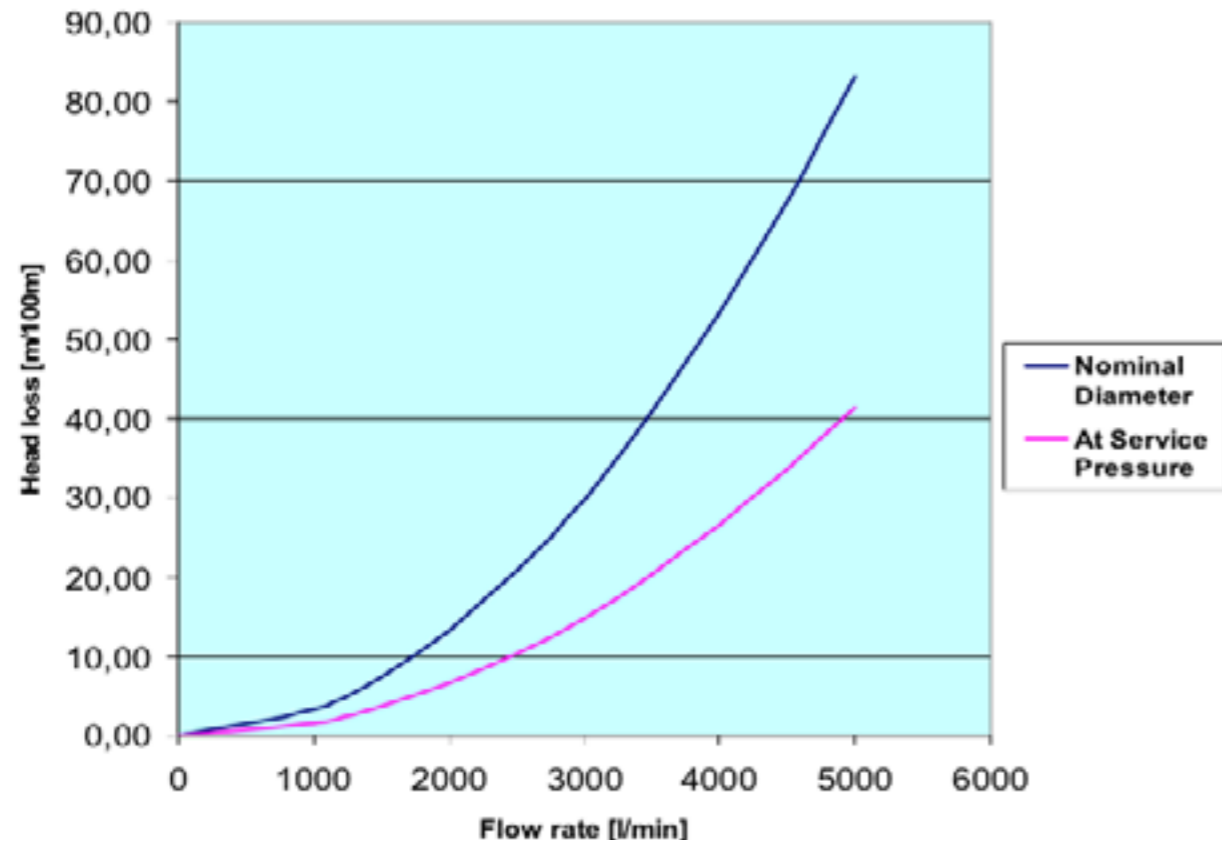

Friction loss Oroflex Flowstream 5"

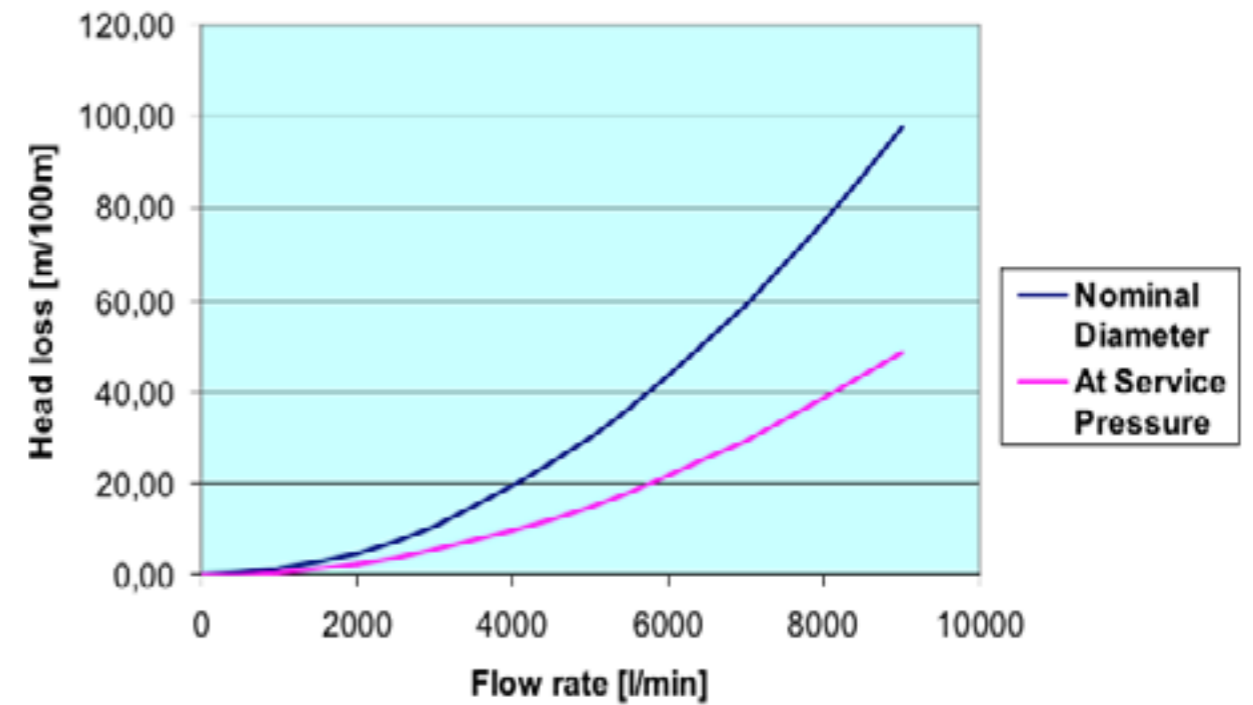

HYDRAULIC PERFORMANCE:

Friction loss Oroflex Flowstream 6"

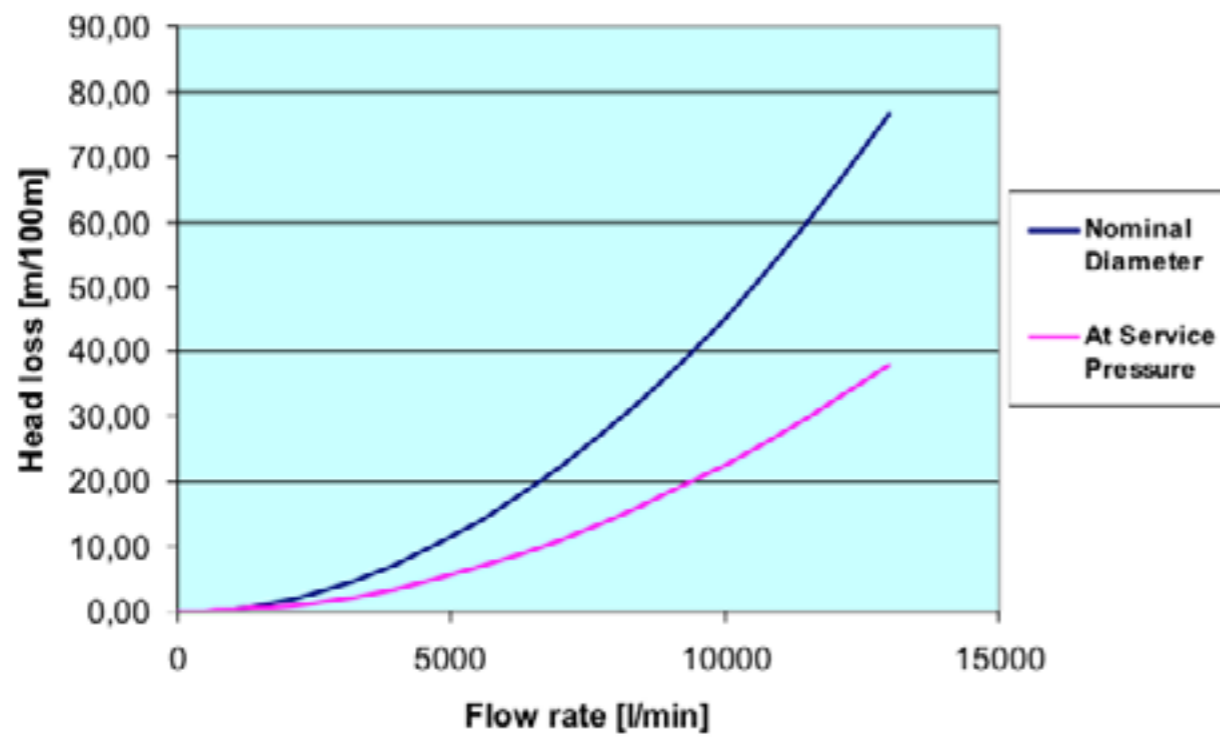

2. INSTALLATION TECHNIQUES FOR OROFLEX FLOWSTREAM FLEXIBLE RISING MAIN SYSTEM

OROFLEX FLOWSTREAM is simple and easy to install compared to rigid risers, requiring less manpower and engineering equipment. The condition of the borehole should be reviewed before installation in order to assess suitability, including casing verticality and diameter. Consult your distributor if necessary.

TO ENSURE SAFE AND CORRECT INSTALLATION OF **OROFLEX FLOWSTREAM**, IT IS IMPORTANT TO FOLLOW THE INSTALLATION INSTRUCTIONS CAREFULLY. NATIONAL AND LOCAL HEALTH AND SAFETY LEGISLATION OR CODES OF PRACTICE SHOULD BE ALSO CONSIDERED.

Although all installations may have individual characteristics, most fall into one of three general installation techniques.

4.1 Vehicle Assisted Installation

4.2 Crane Installation

4.3 Hand Installation

Examples of such installations are expanded in the following sections.

Common to all installation techniques are the procedures for cutting the riser and securing couplings and power cable(s) to **OROFLEX FLOWSTREAM**.

2.1. RISER LENGTH AND COUPLING ATTACHMENT

OROFLEX FLOWSTREAM should be marked approximately every meter along its entire length for guidance purposes. Select the appropriate length according to the required pump setting by subtracting the relevant meter marks if they exist. Where an exact length is required or if there are no marks along the riser, it must be laid out on the ground and cut to length using a tape measure.

Coupling description:

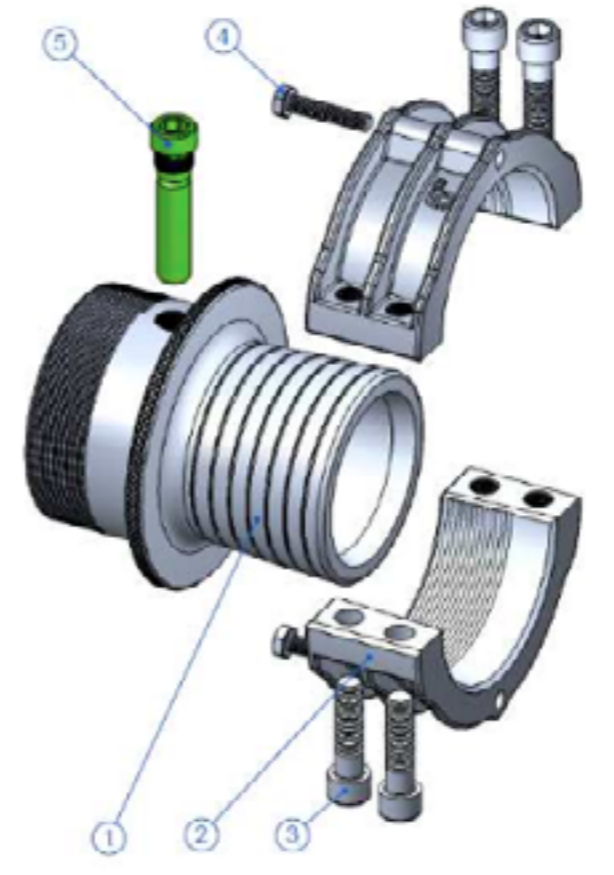

1. Coupling shank
2. Clamp
3. Allen screws (x4)
4. Hexagonal jacking screws (x2)
5. Draining fuse (x1)

2.2. ASSEMBLY PROCEDURE

Using a set square, mark the riser at right angles to its length and cut using a craft knife or hacksaw.

ENSURE THE RISER IS CUT IN A STRAIGHT ANGLE.

One or both couplings may be attached to the riser before installation.

Procedures are as follows:

1. The first step is to take the black strip off from the assembly surface.

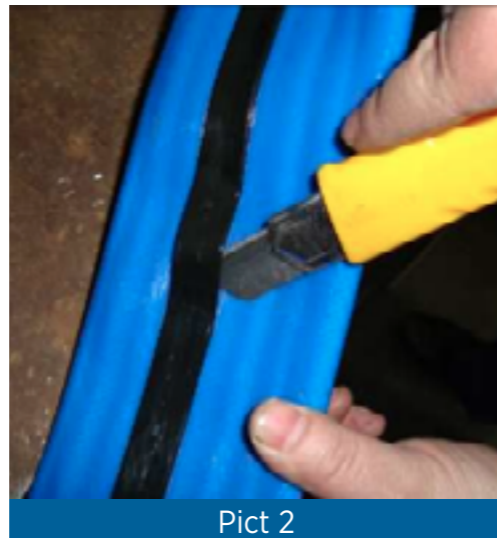

To make it easier, we can try to match the point of the black strip that is not stuck to the hose (look for the loop). (See pictures 1-2).

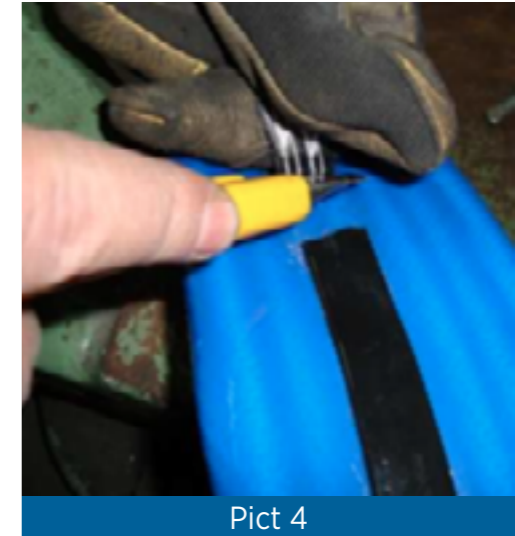
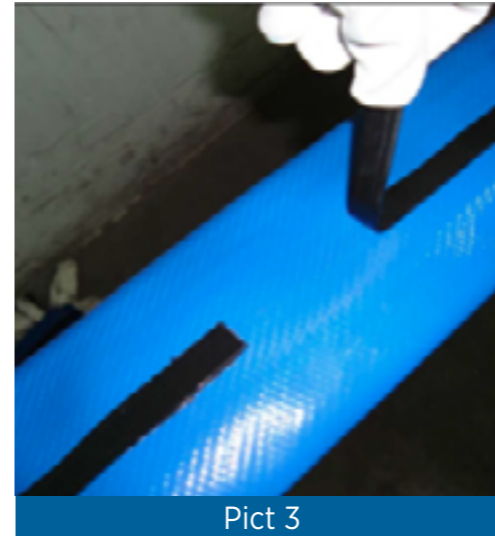

We have to cut the black strip, and then, with a sharp tool we have to cut following where the joint between the blue part and the black part is.

We have to take away enough strip to assure that the black strip is not trapped under the clamp when we the clamp is closed.

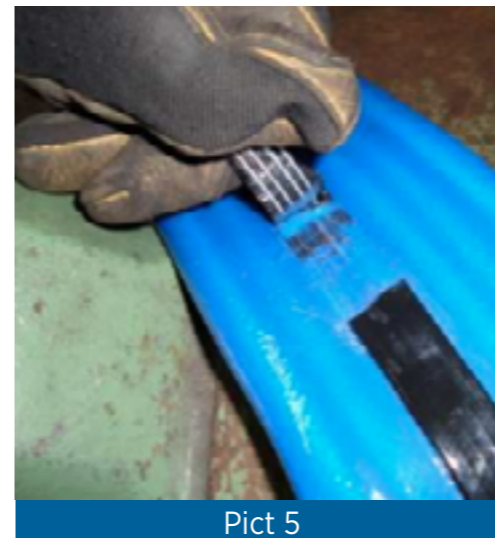

2. The hose has to be cut in a straight line; in a perpendicular angle within the black strip and the hose.



Pict 6



Pict 7



Pict 8

3. Next step is to insert the coupling into the hose. We have to assure that the hose goes to the bottom, so the hose cut edge, has to touch the steel coupling shoulder.

Note: We can fix the coupling, but always protecting the thread.



Pict 9



Pict 10

4. Fit the clamp around the hose, and fix the screws.

It is important to fix the screws in diagonal (like the screws of a car wheel), to assure a homogeneous torque.



Pict 11



Pict 12



Pict 13

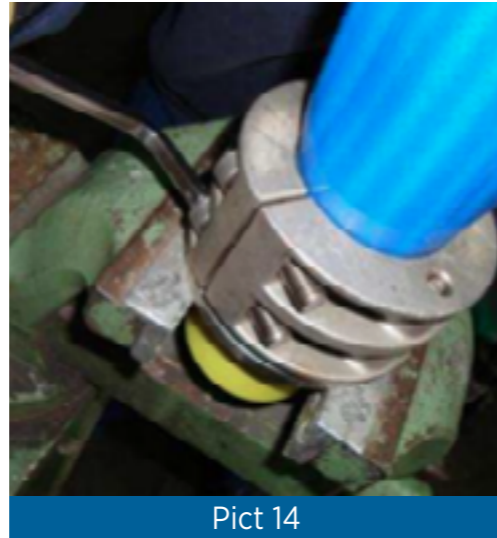

Pict 14



Pict 16



Pict 17



Pict 15

It is very important to check that we can see 3-4 mm of the hose under the clamp.

It is also important to have room enough to introduce a tool to fix the screws.

**5. The last step is to fix the longitudinal screws.
We have to fix them until no further tightening is possible.**

There is no exact fixed measure for this, because it will depend on the thickness of the hose.



Pict 18

3. POWER CABLE ATTACHMENT

Cable Strap Attachment

Attachment loops are provided every 1 metre (approx.) on all riser diameters. On 5” and 6” **OROFLEX FLOWSTREAM**, loops appear on both sides of the riser.

On the first 10m from the pump end, two cable straps per specified loop interval should be used and thereafter use at least the minimum on one unit per loop with specified cable strap.

Check the actual power cable weight before installation and ensure the correct number of cable straps is available. Multi-power cable installations can be fitted to both sides of 5” and 6” **OROFLEX FLOWSTREAM**.

A slack of 2% in general must be installed even if the attachment interval cannot be achieved. Two straps per loop interval must then be used.

RISER DIAMETER		POWER CABLE WEIGHT [kg/m]	CABLE ATTACHMENT SYSTEM		MINIMUM NO. OF CABLE STRAPS PER LOOP INTERVAL	
[mm]	[ins]		PU + Buckle	Saddle Cable Tie	1st 10m from pump ⁽¹⁾	After 1st 10m from pump
38, 51	1½ - 2	< 1.5	X	X	2 every 1m	1 every 1m
51 + 63	2 - 2½	1.5 to 3	X	X	2 every 1m	1 every 1m
76, 102, 125, 152	3, 4, 5, 6	< 3	X	X	2 every 1m	1 every 1m
76, 102, 125, 152	5, 6	3 to 5	X	X	2 every 1m	2 every 1m ⁽²⁾
125, 152	5, 6	> 5	X	NOT APPLICABLE	2 every 1m	2 every 1m ⁽²⁾

⁽¹⁾ A combination of both attachment systems could be used in order to achieve the amount of straps per loop indicated at the table.

⁽²⁾ 5 and 6 inches riser incorporate 2 cable straps a 180°. It is feasible to have an attachment every 0.5 meters in order to achieve the cable straps indicated.

With 51mm and 76mm **OROFLEX FLOWSTREAM**, power cables less than 16mm outer diameter may be secured to the attachment loop without using a saddle.

Multiple single-core power cables should be attached in separate loops, always respecting the recommended minimum slack of 2%.

2 different systems are available for the power cable attachment:

3.1 Polyurethane rounding strap: Recommended for cable with a weight over 4kg/meter

3.2 Saddle + cable tie: Recommended for all type of cables under 4kg/meter.

3.1 Polyurethane rounding strap & stainless steel buckle

NOTE 1: This power cable attachment specification applies to all **OROFLEX FLOWSTREAM** diameters and is specially recommended for cables with a weight above 4kg/meter (most common in 5 and 6" risers) and flat cables.

Recommended knot type for cable attachment:



Step 1

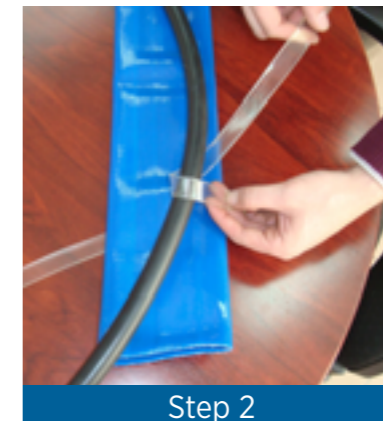

Step 2



Step 3

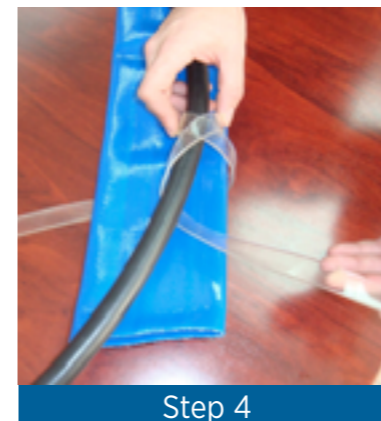

Step 4

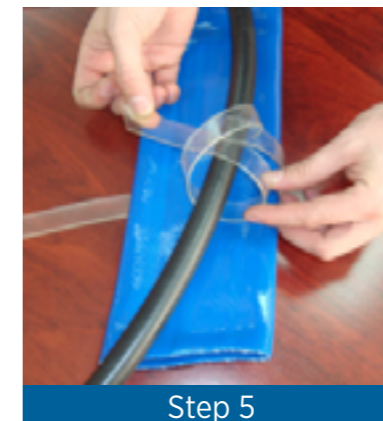

Step 5



Step 6



Step 7



Step 8

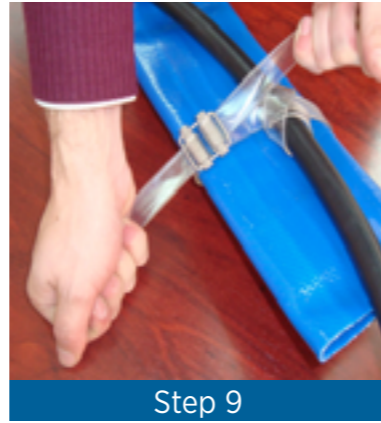

Step 9



The power cable should be fitted as shown in Pict-19 so as to accommodate the extension characteristics of the riser in use.

ROUND SHAPE CABLE



FLAT SHAPE CABLE



Pict 19

3.2 Saddle + cable tie

To accommodate the wide variety of power cable diameters and weights used across the **OROFLEX FLOWSTREAM** size range it may be necessary to use combinations of the two kits listed below.

This system only applies to cables with weight under 4Kg/meter. For cables above 4kg/meter, use the Polyurethane strap and SS buckle system.

Check with your distributor before installation.

- Use 4.8x188mm Polyamide weather resistant cable straps generally for 2" & 3" **OROFLEX FLOWSTREAM**
- Use 7.8x208mm size for - 4", 5", 6" **OROFLEX FLOWSTREAM**. For power cables above approximately 1.5 kg/m, use 7.8x208mm for all **OROFLEX FLOWSTREAM** diameters.

Attachment elements fitting:

1. Push the cable strap through the attachment loop, ensuring the shoulder is located close to the loop.

Note: Initial positioning of the shoulder may vary depending on the power cable diameter, so that the shoulder falls to the side of the power cable after securing.



2. Except for power cables under 16mm diameter, push the saddle over the cable strap and feed the end back through the attachment loop.
3. Bring the cable strap back over the attachment loop and feed it through the saddle again.
4. Pull the two ends of the cable strap until horizontal. If necessary adjust shoulder position.

Power cable attachment:

Position the power cable over the attachment loops, snaking it horizontally for round cables and vertically for flat form cables, ensuring the correct amount of slack is applied. Figure above illustrates a (2%) snake.

ROUND SHAPE CABLE

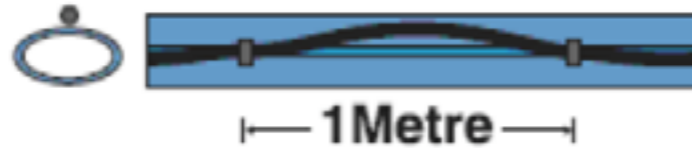

FLAT SHAPE CABLE



Pict 19

Push the cable strap end through the shoulder and tighten using a tensioning tool (Fig. 1.6). N.B. It is important the cable strap firmly grips the power cable which can only be achieved using a tensioning tool.

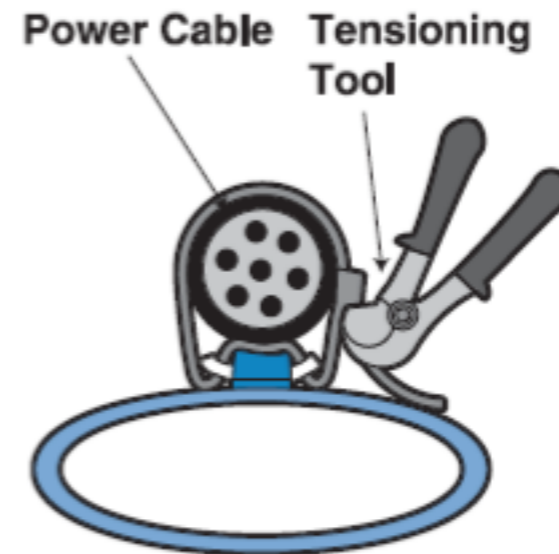

Trim off the surplus strap leaving about 25mm protruding to enable future retightening if necessary.

Accessories' attachment:

Any additional dip tubes, high/low level probes etc, can be attached directly to the power cable or to spare attachment loops using standard cable ties.

Removal of Cable Straps:

Ease the cable strap up using a screw driver and remove:



TOOLS FOR INSTALLING AND RETRIEVING PIPING

a) Roller

Mounting Roller	Measurements
Large mounting roller	1500x840x800
Small mounting roller	750x420x400



Roller

b) Clamps

There are two sizes; the small one is for risers up to 3" (included), and the large clamp is to be used in 4, 5 and 6 inch Oroflex Flowstream hoses.

These are used in order to secure the piping during installation.



Clamps

Instructions for Use:

- Check that there are no sharp protrusions that could damage the riser on the surface or edges of the clamping area.
- Assure that the riser surface in the clamped area is clean and dry, free from water, drilling mud and other potential lubricants.
- The riser is centered and straight in middle of the clamp.
- The power cable is outside the clamp.

Re-check positioning of riser in the clamp and tighten each nut evenly to a torque of 100 Newton-metres for the large clamp and 60 Newton-meters on the small clamp. **Clamp faces must be parallel.**

Safety Precautions:

- At all times the clamp must rest on its feet and be supported by a two leg sling.
- Slings should be attached by shackles, not hooks.
- If we observe that the riser slips from the lifting clamps when we rise all together, lay the clamp and rise again on the ground and re-tight the bolts. Clamp faces must be parallel.

DRAINING DEVICE FOR OROFLEX FLOWSTREAM FLEXIBLE PIPING

This device was designed to empty the water column, the weight of which in many cases makes extraction of the piping difficult. This problem occurs in those installations where a check valve is used at the exit of the pump.

The device is easy to install and use. This system allows the water column to be completely emptied from the well head down to the static level.

The system is composed by two parts: Fuse and torpedo.



Instructions for Use:

Ensure the retrieval cable is firmly attached to the eye of the torpedo and is of sufficient length to reach the bottom of the **OROFLEX FLOWSTREAM** riser. A bar attached to the top of the cable will prevent the cable being lost down the **OROFLEX FLOWSTREAM**.

- Carefully lower the torpedo to the bottom of the **OROFLEX FLOWSTREAM** (An indicator could be when the cable becomes slack).
- Raise the torpedo about 3 meters, release and allow the torpedo to fall under its own weight to shear the break-off plug.
- The water will drain freely down to the static water level. Beyond this, as the **OROFLEX FLOWSTREAM** is withdrawn, allow sufficient time for water to drain out before pulling over the well-head roller or using lifting clamps. Allow 30 seconds per meter for drainage to occur.
- Before replacing the **OROFLEX FLOWSTREAM**, remove the used break-off plug and replace with a new one.

4. INSTALLATION TECHNIQUES:

4.1. VEHICLE ASSISTED INSTALLATION

This method is suitable for installations where a sufficiently large clear area is available to lay out the riser on the ground.

4.1.1 Equipment

- Tools as required in section 6
- Vehicle with suitable towing bracket and mass capability
- Well-head roller
- **OROFLEX FLOWSTREAM** lifting clamps.

A crane may be used in place of a tripod. If a tripod and hoist are used, the vertical lifting height must be sufficient to allow the coupled pump and clamp to be raised above the borehole. When lifting clamps are attached, ensure the riser surface is clean and dry, free from water drilling mud, oils or any other potential lubricant.

4.1.2 Installation

1. Install the tripod and hoist, ensuring that the hoist is positioned centrally above the borehole.
2. Check that the **OROFLEX FLOWSTREAM** clamps and the well-head roller can be readily supported.



3. If a break-off plug is not being used, check the pump non-return valve has been drilled with a 6mm hole.



4. With the pump and coil of **OROFLEX FLOWSTREAM** positioned near the borehole, connect the coupling and riser to the pump (see section 2). Where a flanged pump outlet is used with a cut-out for the power cable, ensure a matching cut-out for the power cable is provided on the coupling flange.
5. Secure the power cable to the base of the riser just above the pump using the appropriate power cable attachment kit (see section 3).
6. Clamp the **OROFLEX FLOWSTREAM** about 500mm above the pump, ensuring the power cable remains outside the clamp.



7. THE CABLE JOINT TO THE PUMP AND ANY PROBES SHOULD BE SECURED TO THE RISER IN THE VERTICAL POSITION AND **NOT ALLOWED TO PASS OVER THE ROLLER.**
8. Carefully raise the pump into position above the borehole, using the shackled hoist attached to the **OROFLEX FLOWSTREAM** clamp. If necessary, prime the pump in accordance with the pump manufacturers' instructions. Lower the pump into the borehole until the clamp is supported over the wellhead, on two cross-beams if necessary.
9. Position the well-head roller above the borehole and firmly secure through the fixing holes using bolts or stakes, to prevent movement during installation. Alternatively, clamps or straps may be used to secure the feet of the roller to a suitable fixing.

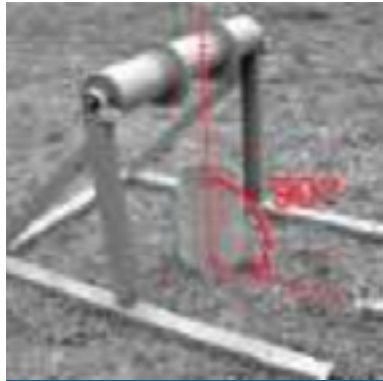

Place the roller on a right angle to the direction of the laid out hose



Roller must be aligned with the casing



Roller must be completely stable

10. Lay out the riser and cable together in a straight line away from the pump as far as is practical, ensuring the location strip (if available) is facing upwards. Cut the riser to the required length. Locate the riser and power cable over the roller.
11. Attach the remainder of the power cable to the riser as described in section 3 together with any additional probes or ancillary equipment.
12. Attach the second **OROFLEX FLOWSTREAM** clamp to the riser either :-
 - 12.1.1. At the far end, if the riser has been fully paid out and installation can be accomplished in one stage.
 - 12.1.2. At the furthest point of retreat for the vehicle (for a two or more stage installation).
13. Secure the second clamp to the vehicle with suitable chains and reverse the vehicle to tension the riser. The excess riser should be passed over and behind the vehicle.

14. Remove the well-head clamp such that the full load is now taken by the vehicle and roller assembly.
15. Drive the vehicle slowly forward, thereby lowering the pump under its own until the second clamp reaches the well-head roller. To avoid excess cable slack which may subsequently contact the casing, **DO NOT ATTACH THE POWER CABLE TO THE RISER OVER THE CLAMP.**



16. Check the security of the cable straps as the riser is lowered.
 17. Joiners, couplings, cable joints, centralizers, probes and clamps must not pass over the roller. Attach a well-head clamp immediately after the joiner (for example) and lift it proud of the roller as the riser is proceeding forward. Remove the clamp immediately afterwards.
 18. When the vehicle approach reaches its limit, clamp and support the riser again at the well-head and then detach the clamp from the vehicle.
- NOTE:** Where two or more stages are necessary, reverse the vehicle and repeat stages **12** to **17**.

19. Lower the remaining riser using both sets of **OROFLEX FLOWSTREAM** clamps, ensuring the tension is always taken by the hoist and upper clamp before the lower clamp is removed. Ensure sufficient riser remains above the borehole (approximately 500mm) to attach the top coupling if necessary.

20. When the correct depth has been reached and the upper clamp is resting on the casing or crossbeams, attach the top coupling and head-works. Lift the head-works on the hoist, remove the **OROFLEX FLOWSTREAM** clamp and lower the assembly onto the borehole. A non-return valve may be incorporated in the head-works as necessary (Fig. 1.16).

NOTE: Suitable slings should be used to support the head-works during the final stages of installation. During commissioning a vent shut-off valve may be required, but an automatic air release valve is not required during normal operation.



IMPORTANT: Under no circumstance the coupling can lean on any object as the well casing, clamp or any other fixed element.

4.2. CRANE INSTALLATION

Where access is limited, vertical installation utilising a mobile crane can be used.

4.2.1 Equipment

- Tools listed in section 6 (except well-head stakes).
- Mobile crane of sufficient lifting capability.
- OROFLEX FLOWSTREAM lifting clamps (light or heavy-duty).

4.2.2 Installation

1. Calculate the maximum height that the crane elevates vertically from the casing. (Refer to drawing, L = length).



2. Place the clamp at a distance from the pump, smaller than that calculated in step 2, in 50cm + the length of the pump. Take into account the following:
 - a) Place the clamp in such a way that it clamps the riser exclusively; one segment of the clamp will be placed between the electrical cable and the riser, and the other one on the opposite side of the riser.
 - b) Firmly tighten bolts to ensure that the riser is perfectly clamped.

3. Lower the clamp using the crane until it is placed above the wellhead and disconnect the hook from the lifting ring of the clamp.



4. If a break-off plug is not being used, check the pump non-return valve has been drilled with a 6mm hole.
5. Position the pump where required and connect the coupling and riser to the pump (see section 3).
6. Clamp the **OROFLEX FLOWSTREAM** about 500mm above the pump ensuring the power cable remains outside the clamp.
7. Lay the riser out, either in a single length for shallow installations or flaked for deeper installations, and cut the riser to the required length (section 2.1).
8. Attach sufficient cable straps and saddles at the required intervals to achieve the maximum possible crane lift and adjust to suit the power cable(s) dimensions. **DO NOT ATTACH THE POWER CABLE AT THIS STAGE.**
9. Attach the hoist from the crane to the clamp and lift the pump into a vertical position. Ensure the pump has been primed before proceeding with the installation.

10. Secure the power cable to the base of the riser just above the pump using the appropriate power cable attachment kit (see section 3).
11. Ensure the section of power cable passing around the base coupling does not contact the casing. If necessary, secure to the coupling with a cable strap.
12. Lower the pump slowly into the borehole, until the **OROFLEX FLOWSTREAM** clamp is supported on the well-head casing, or for larger casing diameters, on two cross beams.



13. Attach the power cable to the rest of the riser following instructions given in sections 2 and 3, always respecting the slack amount and indications described in such sections.

NOTE: The power cable should always be attached to the tensioned riser **AFTER THE FIRST CLAMP HAS BEEN REMOVED** so that no excess slack remains at this point which could subsequently contact the casing.

14. Attach the second **OROFLEX FLOWSTREAM** clamp to the riser to achieve the maximum possible lift. The position will depend on whether the installation can be carried out in one or more stages. Ensure the power cable remains outside the clamp.

15. Remove the hoist from the first **OROFLEX FLOWSTREAM** clamp and attach to the second clamp.



16. Raise the **OROFLEX FLOWSTREAM** with the second clamp until the riser is tensioned and the first clamp is lifted clear of the casing or cross-beams.

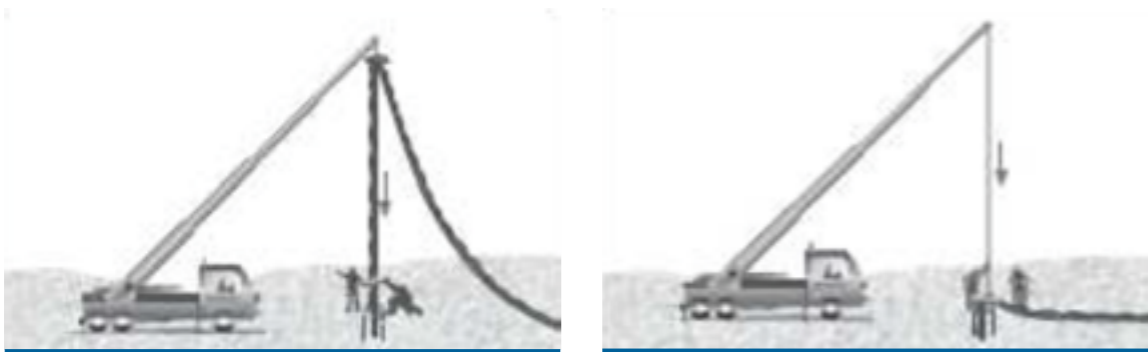

17. Remove the first clamp and lower the riser in to the borehole, until the second clamp comes to rest on the casing or cross-beams. **DO NOT ATTACH ANY HEAD-WORKS FABRICATION UNTIL THE LAST LIFT.**

18. Repeat steps **14** to **18** as many times as necessary to install the riser.

19. Attach the top coupling (if necessary), head-works, lift the head-works with the crane, remove the **OROFLEX FLOWSTREAM** clamp, attach the last cable strap and finally lower the well-head assembly onto the borehole casing.

NOTE: During commissioning a vent shut-off valve may be required, but an automatic air release valve is not required during normal operation.



IMPORTANT: Under no circumstance the coupling can lean on any object as the well casing, clamp or any other fixed element.

4.3 MANUAL INSTALLATION

This method is suitable for installations where the total weight of the pump, power cable and riser is low enough to be installed by hand.

4.3.1 Equipment

- Tools as required in section 6
- Well-head roller
- Light-duty **OROFLEX FLOWSTREAM** lifting clamps

4.3.2 Installation

1. Follow steps 1 to 10 from section 4.2.1
2. Attach the second OROFLEX FLOWSTREAM clamp to the riser either:-
 - At the far end, if the riser has been fully paid out and installation can be accomplished in one stage or not.
 - At the furthest point of retreat available (for a two or more stage installation).
3. Take the tension of the riser by hand with the second clamp, remove the well-head clamp and carefully walk in the riser, lowering the pump under its own weight.
4. Check the security of the cable straps as the riser is lowered.
5. Joiners, couplings, cable joints, centralizers, probes and clamps **must not** pass over the roller.

6. After arriving at the roller, support the riser again at the well-head and detach the second clamp. (Where two or more stages are necessary following 2 to 6 again).
7. To complete the installation, follow steps **19** and **20**.

NOTE: If the installation is extremely lightweight, it may not be necessary to use a tripod and hoist.



IMPORTANT: Under no circumstance the coupling can lean on any object as the well casing, clamp or any other fixed element.

5. RETRIEVAL OF AN OROFLEX FLOWSTREAM FLEXIBLE RISING MAIN SYSTEM

The retrieval technique employed will depend on whether the pump non-return valve has been drilled out or a break-off plug system has been used.

NOTE: Ensure the retrieval device (vehicle, crane or others) can accommodate the full load of the **OROFLEX FLOWSTREAM** system during removal.

5.1 DRILLED NON-RETURN VALVE

1. Stop the pump and allow the water inside the riser to drain down to the static water level. Allow 30 seconds per metre for drainage to occur.
2. Disconnect the electrical supply and discharge pipe work as necessary.
3. Raise the riser and head-works using a crane or hoist (tripod, block and tackle) sufficiently to enable the **OROFLEX FLOWSTREAM** clamp to be applied (power cable must be positioned outside the clamp).
4. Lower the clamp onto the borehole casing or cross-beams placed over the borehole.

5. Remove the head-works. If this necessitates separating the riser from the top coupling, do not cut the riser. Remove the outer clamps and pull the riser from the male body. This facilitates re-attaching the riser in its original position on the coupling and clamps.
6. Prepare the appropriate equipment to commence retrieval, dependant on the removal technique to be used (vehicle/well-head roller, crane, tripod/hoist etc).
7. Follow the installation procedures described in section 4, 5 and 6 in reverse order slowly raising the riser to allow the water to drain down. In vehicle assisted removal, do not allow the pressure to build up at the well-head roller. Stop and wait for drainage to occur. As a guide, allow 30 seconds per metre for drainage.
8. If the **OROFLEX FLOWSTREAM** system is to be reinstalled, it is not necessary to remove the power cable or other attachments. Before replacement, check that the cable straps are in a good condition, re-tight or replace as necessary.

5.2 DRAINING BREAK FUSE SYSTEM

5.2.1 OROFLEX FLOWSTREAM Drainage and Retrieval

1. Stop and disconnect the pump. Remove the well cap to access the top of the riser.
2. Make sure the torpedo is free from burrs.

3. Ensure the retrieval cable is firmly attached to the eye of the torpedo and is of sufficient length to reach the base of the **OROFLEX FLOWSTREAM**. A bar attached to the top of the cable will prevent the cable being lost down the **OROFLEX FLOWSTREAM**.
4. Carefully lower the torpedo to the bottom of the **OROFLEX FLOWSTREAM** (i.e. until the cable becomes slack).
5. Raise the torpedo about 3 metres, release and allow the torpedo to fall under its own weight to shear the break-off plug.
6. The water will drain freely down to the static water level. Beyond this, as the **OROFLEX FLOWSTREAM** is withdrawn, allow sufficient time for water to drain out before pulling over the well-head roller or using lifting clamps.
7. Allow 30 seconds per metre for drainage to occur.
8. Before replacing the **OROFLEX FLOWSTREAM**, remove the used break-off plug and replace with a new one.

6. LIFTING A OROFLEX FLOWSTREAM COLUMN FULL OF WATER

- In the unlikely event that an **OROFLEX FLOWSTREAM** column has to be lifted full of water, additional precautions should be adopted. The weight of the column will be much heavier than normal and a suitable lifting device must be used. Table 2 gives nominal water weights in a 250m length of **OROFLEX FLOWSTREAM** to which, pump, cable, riser and accessories weights should be added.
- Ensure the lifting device can accommodate the total assembly weight before lifting.

In a cylindrical pressurized condition, the nuts on the standard **OROFLEX FLOWSTREAM** clamp cannot be engaged on the threaded bolt in order to flatten the riser together. Two sets of 76mm or 102mm radius ed angle iron bolted 500mm apart will enable the riser to be sufficiently flattened to apply the standard light or heavy duty clamp. Once applied, remove the two sets of angle iron before lifting the riser.

Diameter		Weight	
[ins]	[mm]	[kg]	[lb]
1 ½	38	380	838
2	52	615	1356
2 ½	63	1004	2213
3	76	1380	3042
4	102	2455	5412
5	127	3835	8455
6	152	5520	12170

Table 2

- The top of the column must have an open end to allow the water to drain out as the riser is laid horizontal.
- Horizontal removal via a well-head roller can be used for up to 76mm diameter **OROFLEX FLOWSTREAM**. This technology allows for partial drainage along the lay flat edges of the riser during removal. CARE MUST BE TAKEN TO PREVENT THE BUILD UP OF PRESSURE IN FRONT OF THE WELL-HEAD ROLLER. For large diameters, a clamping technique should be used.
- Alternatively, the riser may be lifted vertically in one stage.

7. CONSIDERATIONS BEFORE INSTALLING THE RISER:

THE WELL:

Check the DEPTH of the bore. If after considering the height at which the pump is to be placed, it is decided to place it closer to the bottom of the well, at least 5 m should be left as a safety margin to protect it from the silt and mud (distance Y in the drawing).

Check the VERTICALITY of the casing. The special features of **OROFLEX FLOWSTREAM** riser make it very adaptable and easy to insert and use in bent or twisted casings. Possible abrasion points of the power cable and probes and the piping itself could be prevented by using centering devices.

The narrowest point of the casing (if not constant) must have a minimum diameter to ensure sufficient clearance for easy insertion and retrieval of the pump. To achieve this, make sure that the maximum diameter of the hose plus cables, or of the pump, or of the couplings plus cables is at least 20 mm less on each side than the internal diameter of the casing (distance X in the drawing).

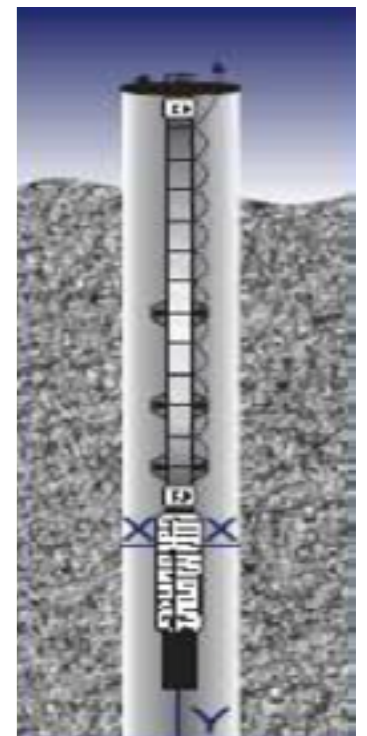

Minimum recommended casing diameter [inches]	1 ½"	2"	2 ½"	3"	4"	5"	6"
	5	5	6	6	8	10	12

These calculations are based on an average standard 200meters installation with the following parameters and power cable size:

RISER SIZE		Diameter with 15% Swell	Power cable maximum diameter/ height*	Clearance	Minimum Casing Diam+
[ins]	[mm]				
1 ½	38	46	12	30	5
2	51	58	16	30	5
2 ½	63	75	20	30	6
3	76	88	20	30	6
4	102	117	25	30	8
5	127	146	35	30	10
6	152	175	45	30	12

For different cable size and well working conditions, all these calculations could be reviewed in order to adjust the riser to the well conditions. Ask to the manufacturer and/or distributor for further details.

8. CENTERING DEVICE

The centering devices prevent the electrical cables from contacting the walls of the well casing, as well as preventing abrasion of the flexible piping in narrow or twisting wells, etc.

The use of centralizers is recommended for installations deeper than 100meters for 4, 5 and 6” **OROFLEX FLOWSTREAM** and above 150 meters in 2 and 3” **OROFLEX FLOWSTREAM** riser systems.

8.1. Instructions of use

1. Look for the loose loops on the riser



2. Depending on the diameter of the riser to install, determine the number of kwik zip segments to use. (Look up the tables below).
3. Lay out the segments and set them up in the first points of their shoulders.

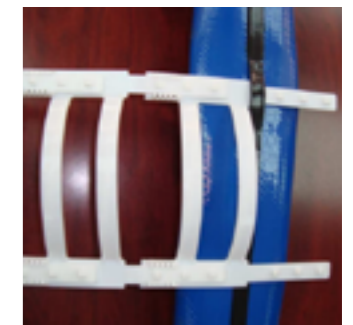

- There are 2 models available in each series (Series 155 and 380). The difference lies in the dimension of the arch or bow height (1.18 " and 2 ").

We recommend using the 2" bow height for hoses above 4 inches as the size of the electric cable would be greater and would be protected in this way.



- The last step for a proper installation is to close the set to the setting point indicated on the tables below, in function of the riser size.



NOTE: IT IS IMPORTANT TO MAINTAIN THE FIXING POSITION (SET-UP POINT) TO ALLOW THE HOSES TO EXPAND IN DIAMETER WITHOUT DAMAGING THE CENTERINGS WHEN THEY ARE UNDER PRESSURE.

CENTRALIZER SETTING POINT:

155 Series:

Oroflex Flowstream		Setting-up point according to working conditions	N° Segments	155 - 1.18"	155 - 2"
inch	mm	Position (mm) - Max 70mm	units	mm	mm
1 ½	38	15	2	102	110
2	51	15	2/3	102	123
2 ½	63	15	3	102	142
3	76	15	3	136	157
4	102	40	3	-	182
5	127	30	4	-	213
6	152	55	4	-	243

380 Series:

Oroflex Flowstream		Setting-up point according to average working conditions	N° Segments	External Diameter 1, 18"	External Diameter 2"
inch	mm	Position (mm) - Max 150mm	units	mm	mm
6	152	46	3	224	245

NOTE1: These centralizers could also be used as a pump centralizer.

NOTE2: The calculations of the setting point of the centralizers have been performed with a swell of 15%. For accurate calculations, a recalculation of the performance of the riser in use could be done, in order to fit the system in narrow casings.

8.2. Installation indications:

Centralizer position in the well

Two centring devices must be placed close to the pump (The first one from the pump has to be located at minimum 500mm from the coupling) and after this, depending on the verticality and conditions of each well. It is recommended to fit 1 centralizer every 20 meters or Oroflex Flowstream riser.

9. TOOLS REQUIRED FOR INSTALLATION AND RETRIEVAL OF OROFLEX FLOWSTREAM

- Stakes or equivalent to restrain well-head roller
- Two cross beams to support clamps
- Power cable strap kits
- Cable strap tensioning tool
- Slings for lifting head-works
- Tripod and restraining chains
- Hoist (block and tackle)
- Metric Allen keys from **M10** to **M16** - right angled and socket type
- Torque wrench - range 6 - 100N-m (4.4 - 74lb-ft).
- Pipe wrench capable of securing 152mm diameter couplings
- 24" stiltson
- Drill and 6mm bit for pump non-return valve
- Soft mallet
- Chain and eyebolts for vehicle with appropriate towing capability
- File and fine emery paper for removing burrs
- Knife and hacksaw
- Set Square
- Ruler
- Clean cloths
- Flat spanner (From M6 to M12)
- PVC electrical insulating tape
- Tape or sealant for power cables
- Installation roller
- Installation clamps (x2)
- Helmet, gloves, safety shoes and any other safety equipment needed for a safe manipulation of the elements involved in the installation.

10. Coupling Specifications

	STANDARD VERSION					NEW MODEL		
Diameter	[mm]	1 ½	2"	2 ½	3"	4"	5"	6"
Material	-	AISI 316	AISI 316	AISI 316	AISI 316	AISI 316	AISI 316	AISI 316
Thread	-	1 ½ BSP/NPT	2" BSP/NPT	2 ½" BSP/NPT	3" BSP/NPT	4" BSP/NPT	5" BSP/NPT	6" BSP/NPT
Max Diameter	[mm]	70	100	95	130	165	196	227
Total Length	[mm]	85	112	100	160	170	185	193
Weight	[kg]	1, 1	2, 4	3, 5	5, 9	8, 3	11	14, 5
Allen Key (DIN912)	[mm]	6	10	8	12	14	16	16
Hexagon Key (DIN933)	[mm]	5	6	8	8	10	10	12
Break off plug - Allen	[mm]	10	10	12	12	20	22	22
Max working pressure	[bar]	40	40	40	40	35	35	35

Oroflex[®]
Flowstream

D-E-S-I-G-N-A-T-I-O-N

Designation Limited

www.oroflex.co.uk

www.desihose.com

Address

Newark Road, Eastern Industry, Peterborough,
PE1 5YD, England

Telephone

01733 893 333

Fax

01733 314 889

Int. Telephone

+44 1733 893 333

Int. Fax

+44 1733 314 889

Email

sales@desihose.com